

Series ONS

SET-3

कोड नं.
Code No. **55/3/S**

रोल नं.
Roll No.

परीक्षार्थी कोड को उत्तर-पुस्तिका के मुख-पृष्ठ पर अवश्य लिखें।

Candidates must write the Code on the title page of the answer-book.

- कृपया जाँच कर लें कि इस प्रश्न-पत्र में मुद्रित पृष्ठ 16 हैं।
- प्रश्न-पत्र में दाहिने हाथ की ओर दिए गए कोड नम्बर को छात्र उत्तर-पुस्तिका के मुख-पृष्ठ पर लिखें।
- कृपया जाँच कर लें कि इस प्रश्न-पत्र में 26 प्रश्न हैं।
- कृपया प्रश्न का उत्तर लिखना शुरू करने से पहले, प्रश्न का क्रमांक अवश्य लिखें।
- इस प्रश्न-पत्र को पढ़ने के लिए 15 मिनट का समय दिया गया है। प्रश्न-पत्र का वितरण पूर्वाह्न में 10.15 बजे किया जाएगा। 10.15 बजे से 10.30 बजे तक छात्र केवल प्रश्न-पत्र को पढ़ेंगे और इस अवधि के दौरान वे उत्तर-पुस्तिका पर कोई उत्तर नहीं लिखेंगे।
- Please check that this question paper contains 16 printed pages.
- Code number given on the right hand side of the question paper should be written on the title page of the answer-book by the candidate.
- Please check that this question paper contains 26 questions.
- **Please write down the Serial Number of the question before attempting it.**
- 15 minute time has been allotted to read this question paper. The question paper will be distributed at 10.15 a.m. From 10.15 a.m. to 10.30 a.m., the students will read the question paper only and will not write any answer on the answer-book during this period.

भौतिक विज्ञान (सैद्धान्तिक)

PHYSICS (Theory)

निर्धारित समय : 3 घण्टे

अधिकतम अंक : 70

Time allowed : 3 hours

Maximum Marks : 70

55/3/S

1

P.T.O.



सामान्य निर्देश :

- (i) सभी प्रश्न अनिवार्य हैं। इस प्रश्न-पत्र में कुल 26 प्रश्न हैं।
- (ii) इस प्रश्न-पत्र के 5 भाग हैं : खण्ड अ, खण्ड ब, खण्ड स, खण्ड द और खण्ड य।
- (iii) खण्ड अ में 5 प्रश्न हैं, प्रत्येक का 1 अंक है। खण्ड ब में 5 प्रश्न हैं, प्रत्येक के 2 अंक हैं। खण्ड स में 12 प्रश्न हैं, प्रत्येक के 3 अंक हैं। खण्ड द में 4 अंक का एक मूल्याधारित प्रश्न है और खण्ड य में 3 प्रश्न हैं, प्रत्येक के 5 अंक हैं।
- (iv) प्रश्न-पत्र में समग्र पर कोई विकल्प नहीं है। तथापि, दो अंकों वाले एक प्रश्न में, तीन अंकों वाले एक प्रश्न में और पाँच अंकों वाले तीनों प्रश्नों में आन्तरिक चयन प्रदान किया गया है। ऐसे प्रश्नों में आपको दिए गए चयन में से केवल एक प्रश्न ही करना है।
- (v) जहाँ आवश्यक हो आप निम्नलिखित भौतिक नियतांकों के मानों का उपयोग कर सकते हैं :

$$c = 3 \times 10^8 \text{ m/s}$$

$$h = 6.63 \times 10^{-34} \text{ Js}$$

$$e = 1.6 \times 10^{-19} \text{ C}$$

$$\mu_0 = 4\pi \times 10^{-7} \text{ T m A}^{-1}$$

$$\epsilon_0 = 8.854 \times 10^{-12} \text{ C}^2 \text{ N}^{-1} \text{ m}^{-2}$$

$$\frac{1}{4\pi\epsilon_0} = 9 \times 10^9 \text{ N m}^2 \text{ C}^{-2}$$

$$m_e = 9.1 \times 10^{-31} \text{ kg}$$

$$\text{न्यूट्रॉन का द्रव्यमान} = 1.675 \times 10^{-27} \text{ kg}$$

$$\text{प्रोटॉन का द्रव्यमान} = 1.673 \times 10^{-27} \text{ kg}$$

$$\text{आवोगाद्रो संख्या} = 6.023 \times 10^{23} \text{ प्रति ग्राम मोल}$$

$$\text{बोल्ट्ज़मान नियतांक} = 1.38 \times 10^{-23} \text{ JK}^{-1}$$

General Instructions :

- (i) *All questions are compulsory. There are 26 questions in all.*
- (ii) *This question paper has five sections : Section A, Section B, Section C, Section D and Section E.*
- (iii) *Section A contains five questions of one mark each, Section B contains five questions of two marks each, Section C contains twelve questions of three marks each, Section D contains one value based question of four marks and Section E contains three questions of five marks each.*
- (iv) *There is no overall choice. However, an internal choice has been provided in one question of two marks, one question of three marks and all the three questions of five marks weightage. You have to attempt only one of the choices in such questions.*
- (v) *You may use the following values of physical constants wherever necessary.*

$$c = 3 \times 10^8 \text{ m/s}$$

$$h = 6.63 \times 10^{-34} \text{ Js}$$

$$e = 1.6 \times 10^{-19} \text{ C}$$

$$\mu_0 = 4\pi \times 10^{-7} \text{ T m A}^{-1}$$

$$\epsilon_0 = 8.854 \times 10^{-12} \text{ C}^2 \text{ N}^{-1} \text{ m}^{-2}$$

$$\frac{1}{4\pi\epsilon_0} = 9 \times 10^9 \text{ N m}^2 \text{ C}^{-2}$$

$$m_e = 9.1 \times 10^{-31} \text{ kg}$$

$$\text{Mass of neutron} = 1.675 \times 10^{-27} \text{ kg}$$

$$\text{Mass of proton} = 1.673 \times 10^{-27} \text{ kg}$$

$$\text{Avogadro's number} = 6.023 \times 10^{23} \text{ per gram mole}$$

$$\text{Boltzmann constant} = 1.38 \times 10^{-23} \text{ JK}^{-1}$$

खण्ड - अ
SECTION - A

1. नीचे परिपथ में P और Q द्वारा अंकित तर्क गेटों को पहचानिए। 1

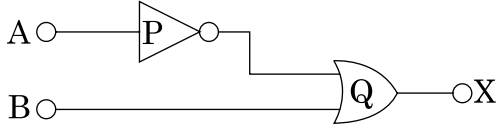

Name the logic gates marked P and Q in the given logic circuit.

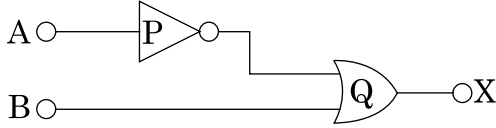

2. दो तार जिनमें एक कॉपर तथा दूसरा मैंगनिन का है, की लम्बाइयां समान तथा प्रतिरोध भी समान हैं। इनमें कौन सा तार अधिक मोटा है? 1

Two wires one of copper and other of manganin have same resistance and equal length. Which wire is thicker and why ?

3. किसी चालक में “विश्रांति-काल’ पद की परिभाषा लिखिए। 1

Define the term ‘relaxation time’ in a conductor.

4. उस स्थिति का उल्लेख कीजिए जिसमें विस्थापन धारा तो होती है परन्तु चालन धारा नहीं होती। 1

In which situation is there a displacement current but no conduction current ?

5. किसी a.c. परिपथ का शक्ति गुणांक 0.5 है। परिपथ में वोल्टता और धारा के बीच कलान्तर क्या है? 1

The power factor of an a.c. circuit is 0.5. What is the phase difference between voltage and current in the circuit ?

खण्ड - ब
SECTION - B

6. हाइड्रोजन परमाणु की निम्नतम अवस्था में, बोर त्रिज्या $5.3 \times 10^{-11} \text{ m}$ दी गयी है। इस परमाणु को इतना उत्तेजित किया जाता है कि उसकी त्रिज्या $21.2 \times 10^{-11} \text{ m}$ हो जाती है। इस उत्तेजक अवस्था में (i) मुख्य क्वाण्टम अंक का मान तथा (ii) उत्तेजित अवस्था में परमाणु की कुल ऊर्जा ज्ञात कीजिए। 2

अथवा

किसी परिकल्पित परमाणु के ऊर्जा स्तर नीचे दिए गए हैं। दर्शाए गए संक्रमणों में से किसमें 275 nm तरंगदैर्घ्य का फोटॉन उत्सर्जित होगा ?

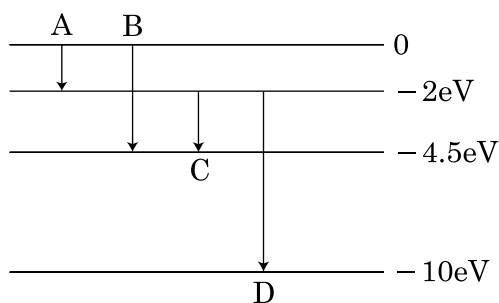

In the ground state of hydrogen atom, its Bohr radius is given as $5.3 \times 10^{-11} \text{ m}$. The atom is excited such that the radius becomes $21.2 \times 10^{-11} \text{ m}$. Find (i) the value of the principal quantum number and (ii) the total energy of the atom in this excited state.

OR

The energy levels of a hypothetical atom are shown below. Which of the shown transitions will result in the emission of photon of wavelength 275 nm ?

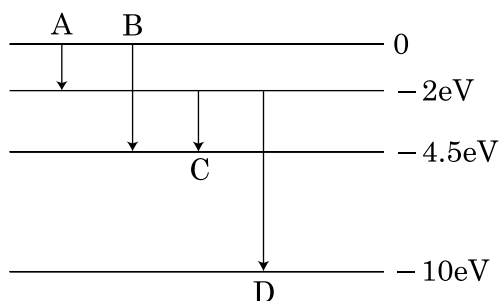

7. संचार के संदर्भ में (i) ट्रान्सड्यूसर और (ii) पुनरावर्तक का कार्य लिखिए। 2

Write the function of a (i) transducer and (ii) repeater in a communication system.

8. वैद्युत चुम्बकीय तरंगों के दो गुणों का वर्णन कीजिए। आप यह किस प्रकार दर्शाते हैं कि वैद्युत चुम्बकीय तरंगें संवेग वहन करती हैं? 2

State two properties of electromagnetic waves. How can we show that em waves carry momentum ?

9. डेविसन-जर्मर प्रयोग में इलेक्ट्रॉन की तरंग प्रकृति के प्रायोगिक प्रमाण के लिए आधारित सिद्धांत का संक्षेप में उल्लेख कीजिए। 120 eV गतिज ऊर्जा के इलेक्ट्रॉन की दे ब्राग्ली तरंगदैर्घ्य क्या होती है? 2

Write briefly the underlying principle used in Davison-Germer experiment to verify wave nature of electrons experimentally. What is the de-Broglie wavelength of an electron with kinetic energy (K.E.) 120 eV ?

10. स्थिर - वैद्युत परिरक्षण क्या है? वास्तविक व्यवहार में इस गुण का उपयोग कैसे किया जाता है? क्या किसी आवेशित चालक की गुहिका में विभव शून्य होता है? 2

What is electrostatic shielding ? How is this property used in actual practice ? Is the potential in the cavity of a charged conductor zero ?

खण्ड - स
SECTION - C

11. एकवर्णी प्रकाश की दो गुणावृत्ति तरंगों

3

$$y_1 = a \cos wt \text{ तथा } y_2 = a \cos(wt + \phi)$$

एक दूसरे पर अध्यारोपण करती हैं। यह दर्शाइए कि व्यतिकरण पैटर्न में अधिकतम तीव्रता प्रत्येक झिरी के कारण तीव्रता की चार गुनी होती है। इस प्रकार, कला कोण ϕ के पदों में संपोषी और विनाशी व्यतिकरण के लिए शर्तें लिखिए।

Two harmonic waves of monochromatic light

$$y_1 = a \cos wt \text{ and } y_2 = a \cos(wt + \phi)$$

are superimposed on each other. Show that maximum intensity in interference pattern is four times the intensity due to each slit. Hence write the conditions for constructive and destructive interference in terms of the phase angle ϕ .

12. (i) प्रकाश उत्सर्जक डायोड (LED) में प्रकाश उत्सर्जन की प्रक्रिया का संक्षेप में वर्णन कीजिए।

3

(ii) LED के निर्माण के लिए किन अर्धचालकों को प्राथमिकता दी जाती है और क्यों?

(iii) रुद्धिगत तापदीप्त लैम्पों की तुलना में LED बल्बों का उपयोग करने के दो लाभ लिखिए।

(i) Explain briefly the process of emission of light by a Light Emitting Diode (LED).

(ii) Which semiconductors are preferred to make LEDs and why ?

(iii) Give two advantages of using LEDs over conventional incandescent lamps.

13. (i) नर्म लौह के उन दो गुणों का उल्लेख कीजिए जिनके कारण विद्युतचुम्बक बनाने के लिए इसे प्राथमिकता दी जाती है।

3

(ii) चुम्बकत्व में गाउस का नियम लिखिए। स्थिर विद्युत के लिए गाउस के नियम से यह किस प्रकार भिन्न है और क्यों?



अथवा

त्रिज्या r तथा $2l$ लम्बाई के किसी परिमित सॉलैनाइड (परिनालिका) जिससे धारा I प्रवाहित हो रही है, के अक्षीय चुम्बकीय क्षेत्र के लिए व्यंजक व्युत्पन्न कीजिए। किस स्थिति में यह क्षेत्र किसी छड़ चुम्बक द्वारा उत्पन्न चुम्बकीय क्षेत्र के समतुल्य हो जाता है?

- (i) Mention two properties of soft iron due to which it is preferred for making an electromagnet.
- (ii) State Gauss's law in magnetism. How is it different from Gauss's law in electrostatics and why ?

OR

Derive an expression for the axial magnetic field of a finite solenoid of length $2l$ and radius r carrying current I . Under what condition does the field become equivalent to that produced by a bar magnet ?

14. 50 Hz आवृत्ति और 200 V के किसी ac स्रोत से श्रेणी क्रम में अज्ञात धारिता का कोई संधारित्र, 100Ω का कोई प्रतिरोध और स्वप्रेरकत्व $L = (4/\pi^2)$ हेनरी का कोई प्रेरक संयोजित है। उस स्थिति में जब धारा तथा वोल्टता समान कला में हैं, इस परिपथ की धारिता और प्रतिबाधा का मान परिकलित कीजिए। इस परिपथ में क्षयित शक्ति भी परिकलित कीजिए। 3

A capacitor of unknown capacitance, a resistor of 100Ω and an inductor of self inductance $L = (4/\pi^2)$ henry are connected in series to an ac source of 200V and 50 Hz. Calculate the value of the capacitance and impedance of the circuit when the current is in phase with the voltage. Calculate the power dissipated in the circuit.

15. इंटरनेट के किन्हीं तीन अनुप्रयोगों का उल्लेख कीजिए। इनमें से किसी एक का विस्तार में वर्णन कीजिए। 3

Mention any three applications of the internet. Explain one of these in detail.

16. (a) किसी समान्तर पट्टिका संधारित्र (C_1) जिस पर कोई आवेश Q है; को एक सर्वसम, अनावेशित संधारित्र C_2 से श्रेणी क्रम में संयोजित किया गया है। इस प्रकरण में संधारित्र C_2 पर कितना आवेश एकत्रित होगा? 3
- (b) तीन सर्वसम संधारित्रों, जिनमें प्रत्येक की धारिता $3\mu\text{F}$ है को बारी-बारी से पहले श्रेणी और फिर पार्श्व क्रम में संयोजित करके V वोल्ट की किसी बैटरी से संयोजित किया जाता है। संचित ऊर्जाओं का अनुपात ज्ञात कीजिए।
- (a) A parallel plate capacitor (C_1) having charge Q is connected, to an identical uncharged capacitor C_2 in series. What would be the charge accumulated on the capacitor C_2 ?
- (b) Three identical capacitors each of capacitance $3\mu\text{F}$ are connected, in tern, in series and in parallel combination to the common source of V volt. Find out the ratio of the energies stored in two configurations.

17. द्रव्यमान संख्या के फलन के रूप में बंधन ऊर्जा प्रति न्यूक्लियॉन का विचरण दर्शाने के लिए ग्राफ खींचिए। नाभिकीय बल का कौनसा गुण $30 < A < 170$ परिसर में बंधन ऊर्जा की सन्निकट स्थिरता की व्याख्या करता है? इस ग्राफ की सहायता से नाभिकीय विखण्डन और नाभिकीय संलयन दोनों ही प्रक्रियाओं में ऊर्जा मुक्त होने की व्याख्या किस प्रकार की जा सकती है? 3

Plot a graph showing the variation of binding energy per nucleon as a function of mass number. Which property of nuclear force explains the approximate constancy of binding energy in the range $30 < A < 170$? How does one explain the release of energy in both the processes of nuclear fission and fusion from the graph?

18. n-p-n ट्रॉन्जिस्टर के उपयोग को दर्शाते हुए उभयनिष्ठ उत्सर्जक प्रवर्धक का विद्युत परिपथ खींचिए। धारा लब्धि β_{ac} के लिए व्यंजक व्युत्पन्न कीजिए। 3

Draw a circuit diagram of a common emitter amplifier using n-p-n transistor. Derive an expression for the current gain β_{ac} .

19. (a) फोटॉन चित्रण में “विकिरण - तीव्रता’ पद की परिभाषा कीजिए। 3
- (b) तीन विभिन्न तीव्रताओं $I_1 > I_2 > I_3$, जिनमें से दो (I_1 और I_2) की समान आवृत्तियाँ ν हैं तथा तीसरी की आवृत्ति $\nu_1 > \nu$ है, के लिए प्रकाश विद्युत और संग्राहक विभव के बीच विचरण को दर्शाने के लिए ग्राफ खींचिए।
- (c) आइंस्टीन समीकरण के आधार पर वक्र की प्रकृति की व्याख्या कीजिए।
- (a) Define the term ‘intensity of radiation’ in photon picture.
- (b) Plot a graph showing the variation of photo current vs collector potential for three different intensities $I_1 > I_2 > I_3$, two of which (I_1 and I_2) have the same frequency ν and the third has frequency $\nu_1 > \nu$.
- (c) Explain the nature of the curves on the basis of Einstein’s equation.
20. (i) किसी कांच के प्रिज़्म ($\mu = \sqrt{3}$) के लिए न्यूनतम विचलन कोण प्रिज़्म कोण के बराबर 3 है। प्रिज़्म कोण का मान परिकलित कीजिए।
- (ii) उस स्थिति के लिए, जिसमें अपवर्तनांक $\mu = \sqrt{3}$ के किसी समकोणिक समद्विबाहु कांच के प्रिज़्म के दो समान फलकों में से किसी एक पर प्रकाश किरण अभिलम्बवत आपतन करती है, किरण आरेख खींचिए।
- (i) For a glass prism ($\mu = \sqrt{3}$) the angle of minimum deviation is equal to the angle of the prism. Calculate the angle of the prism.
- (ii) Draw ray diagram when incident ray falls normally on one of the two equal sides of a right angled isosceles prism having refractive index $\mu = \sqrt{3}$.
21. (i) उस परिघटना का नाम लिखिए जिस पर प्रकाशिक तन्तु की क्रियाविधि आधारित है। 3
- (ii) इस परिघटना के होने के लिए आवश्यक शर्तें लिखिए।
- (iii) प्रकाशित तन्तु का नामांकित आरेख खींचकर यह दर्शाइए कि इस परिघटना के उपयोग से प्रकाशिक तन्तु से प्रकाश संचरण किस प्रकार होता है।
- (i) Name the phenomenon on which the working of an optical fibre is based.
- (ii) What are the necessary conditions for this phenomenon to occur ?
- (iii) Draw a labelled diagram of an optical fibre and show how light propagates through the optical fibre using this phenomenon.



22. लम्बाई $2a$ और द्विध्रुव आघूर्ण \vec{p} के किसी वैद्युत द्विध्रुव की विषुवत रेखा के किसी बिन्दु पर विद्युत क्षेत्र तीव्रता के लिए व्यंजक व्युत्पन्न कीजिए। इस क्षेत्र की दिशा का उल्लेख भी कीजिए। 3

Derive an expression for the electric field intensity at a point on the equatorial line of an electric dipole of dipole moment \vec{p} and length $2a$. What is the direction of this field ?

खण्ड - द

SECTION - D

23. बादलों की गर्जन के समय किसी शक्ति संचरण लाइन का विद्युन्मय तार धरती पर गिर गया। लड़कों का एक समूह जो वहाँ से गुजर रहा था, उसने इस तार को देखा और उनमें से कुछ लड़के उस तार को एक ओर करना चाहते थे। जैसे ही वे उस तार के निकट जाकर उसे उठाने का प्रयास कर रहे थे, हरी ने इसे देखा और तुरन्त ही उन्हें तार से दूर धकेलते हुए, उस तार को छूने से रोका। इस प्रक्रिया के समय दो को चोट भी लग गयी। हरी उन्हें चिकित्सा सहायता के लिए डॉक्टर के पास ले गया। 4

उपरोक्त गद्यांश के आधार पर नीचे दिए गए प्रश्नों के उत्तर दीजिए :

- (a) इस घटना के समय हरी द्वारा प्रदर्शित दो मूल्य लिखिए।
- (b) ऐसा क्यों है कि लटके विद्युन्मय तार पर चिड़िया बैठ सकती है और उसे कोई चोट नहीं लगती, जबकि धरती से इसी तार को स्पर्श करने पर घातक झटका लग सकता है?
- (c) किसी शक्ति संयंत्र पर विद्युत शक्ति को दूरस्थ उपभोक्ताओं तक संचरण से पूर्व अति उच्च वोल्टता पर प्रतिष्ठित किया जाता है। इसका कारण लिखिए।

During a thunderstorm the 'live' wire of the transmission line fell down on the ground. A group of boys passing through noticed it and some of them wanted to place the wire by the side. As they were approaching the wire and trying to lift it, Hari noticed it and immediately pushed them away to prevent them from touching the wire. Two of them got hurt in the process. Hari took them to a doctor to get medical aid.

Based on the above paragraph, answer the following :

- Write two values which Hari displayed during the incident.
- Why is it that a bird can sit over a suspended 'live' wire without any harm whereas touching it on the ground can give a fatal shock ?
- The electric power from a power plant is set up to a very high voltage before transmitting it to distant consumers. Write the reason for it.

खण्ड - य

SECTION - E

24. (i) बायो-सर्वट नियम लिखिए और इसे सदिश रूप में व्यक्त कीजिए। 5
- (ii) इस नियम का उपयोग R त्रिज्या की धारावाही कुण्डली, जिससे धारा I प्रवाहित हो रही है की अक्षीय रेखा पर स्थित किसी बिन्दु, जिसकी कुण्डली के केन्द्र से दूरी d है, पर चुम्बकीय क्षेत्र के लिए व्यंजक प्राप्त करने में कीजिए।
- (iii) इसी कुण्डली के केन्द्र पर तथा अक्षीय बिन्दु, जिसके लिए $x = R\sqrt{3}$ है, पर चुम्बकीय क्षेत्रों के परिमाणों का अनुपात भी ज्ञात कीजिए।

अथवा

- परिवर्ती चालों से गतिमान आवेशित कणों के किसी पुन्ज पर विचार कीजिए। यह दर्शाइए कि क्रासित विद्युत एवं चुम्बकीय क्षेत्रों का उपयोग किसी विशेष चाल से गतिशील आवेशित कणों के चयन के लिए किस प्रकार किया जा सकता है।
- किसी अन्य युक्ति/मशीन का नाम लिखिए जिसमें क्रासित विद्युत एवं चुम्बकीय क्षेत्रों का उपयोग किया जाता है। यह मशीन क्या करती है और इस मशीन में चुम्बकीय और विद्युत क्षेत्रों का क्या कार्य है? इस मशीन में ये क्षेत्र कहां होते हैं? इनकी प्रकृति के विषय में लिखिए।



- (i) Express Biot-Savart law in the vector form.
- (ii) Use it to obtain the expression for the magnetic field at an axial point, distance d from the centre of a circular coil of radius R carrying current I .
- (iii) Also, find the ratio of the magnitudes of the magnetic field of this coil at the centre and at an axial point for which $x = R\sqrt{3}$.

OR

- (a) Consider a beam of charged particles moving with varying speeds. Show how crossed electric and magnetic fields can be used to select charged particles of a particular velocity ?
- (b) Name another device/machine which uses crossed electric and magnetic fields. What does this machine do and what are the functions of magnetic and electric fields in this machine ? Where do these field exist in this machine ? Write about their natures.

25. तरंगदैर्घ्य ' λ ' के किसी एकवर्णी प्रकाश स्रोत से जब कोई समान्तर पुन्ज 'a' चौड़ाई की किसी एकल झिरी पर आपतन करता है, तो यह दर्शाए कि झिरी पर तरंगिकाओं के व्यतिकरण के कारण पर्दे पर विवर्तन पैटर्न किस प्रकार बनता है। 5

यह दर्शाए कि $\theta=0$ पर केन्द्रीय उच्चिष्ठ के साथ-साथ $\theta = \left(n + \frac{1}{2} \right) \lambda / a$ पर द्वितीयक उच्चिष्ठ और $\theta = n\lambda/a$ पर निम्निष्ठ दिखाई देते हैं।

n में वृद्धि होने पर द्वितीयक उच्चिष्ठ तीव्रता में दुर्बल क्यों होता जाता है? व्याख्या कीजिए।

अथवा

- (i) R वक्रता त्रिज्या के किसी गोलीय पृष्ठ के उत्तल फलक की ओर मुख्य अक्ष पर स्थित किसी बिन्दुकित बिम्ब का प्रतिबिम्ब बनने की ज्यामिति को दर्शाने के लिए किरण आरेख खींचिए। यह मानते हुए कि प्रकाश किरण n_1 अपवर्तनांक के किसी विरल माध्यम से n_2 अपवर्तनांक के सघन माध्यम पर आपतन करती है।

$$\frac{n_2}{v} - \frac{n_1}{u} = \frac{n_2 - n_1}{R} \text{ सूत्र का व्युत्पन्न कीजिए।}$$

यहाँ पर प्रतीकों के सामान्य अर्थ हैं।

- (ii) व्याख्या कीजिए कि किसी उत्तल लेंस की फोकस दूरी आपतित प्रकाश की तरंगदैर्घ्य में वृद्धि होने पर किस प्रकार परिवर्तित होती है।
- (iii) किसी उत्तल लेंस को जल में डुबोने पर उसकी फोकस दूरी का क्या होता है? लेंस के पदार्थ का अपवर्तनांक जल के अपवर्तनांक से अधिक है।



When a parallel beam of monochromatic source of light of wavelength λ is incident on a single slit of width a , show how the diffraction pattern is formed at the screen by the interference of the wavelets from the slit.

Show that, besides the central maximum at $\theta = 0$, secondary maxima are observed at $\theta = \left(n + \frac{1}{2}\right)\lambda/a$ and the minima at $\theta = n\lambda/a$.

Why do secondary maxima get weaker in intensity with increasing n ? Explain.

OR

- (i) Draw a ray diagram showing the geometry of formation of image of a point object situated on the principal axis and on the convex side of a spherical surface of radius of curvature R . Taking the rays as incident from a rarer medium of refractive index n_1 to a denser medium of refractive index n_2 , derive the relation.

$$\frac{n_2}{v} - \frac{n_1}{u} = \frac{n_2 - n_1}{R}, \text{ where symbols have their usual meaning.}$$

- (ii) Explain briefly how the focal length of a convex lens changes with increase in wavelength of incident light.
- (iii) What happens to the focal length of convex lens when it is immersed in water? Refractive index of the material of lens is greater than that of water.



26. (i) नीचे दिए गए परिपथ में $1\ \Omega$ प्रतिरोध से प्रवाहित धारा एवं दिशा ज्ञात कीजिए।

5

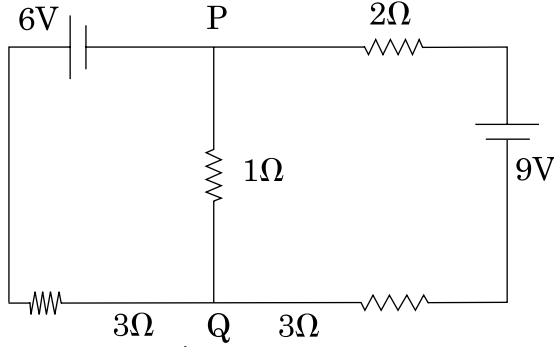

- (ii) दो छात्र X और Y नीचे दर्शाए परिपथ का उपयोग करते हुए पोटैन्शियोमीटर पर अलग-अलग प्रयोग करते हैं।

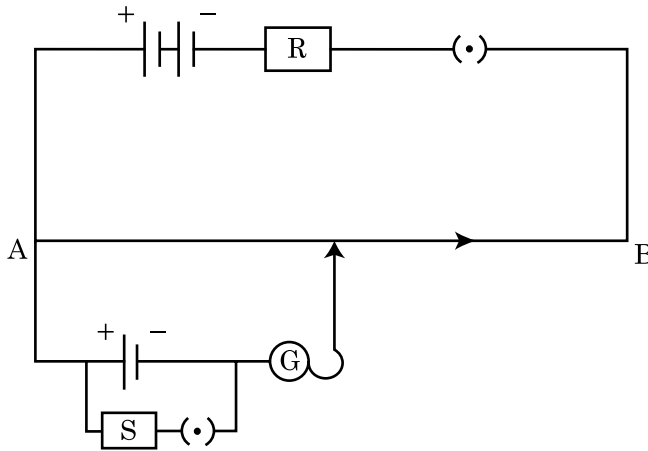

अन्य कारकों को अपरिवर्तित रखते हुए (a) 'X' प्रतिरोध R के मान में वृद्धि करता है, (b) 'Y' इस व्यवस्था में प्रतिरोध S के मान को कम करता है। इन परिवर्तनों से प्रत्येक प्रकरण में उदासीन बिन्दु की स्थिति किस प्रकार प्रभावित होगी और क्यों?

अथवा

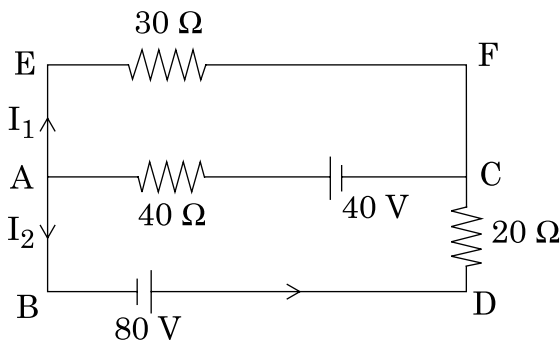

- (a) किरखोफ के नियमों का उपयोग करके उपरोक्त परिपथ की भुजा AC में धारा परिकलित कीजिए।
 (b) मीटर सेतु का कार्यकारी सिद्धान्त क्या है? इस सेतु में धातु की पट्टियों का उपयोग क्यों किया जाता है?

- (i) Find the magnitude and direction of current in $1\ \Omega$ resistor in the given circuit.

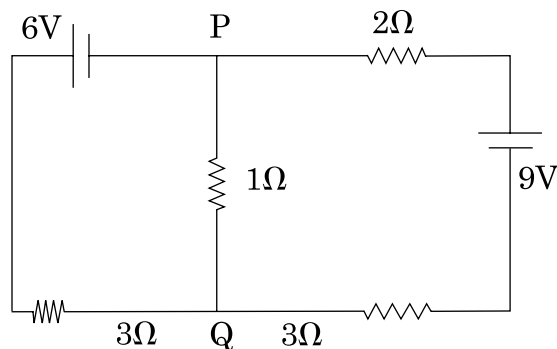

- (ii) Two students X and Y perform an experiment on potentiometer separately using the circuit diagram shown below.

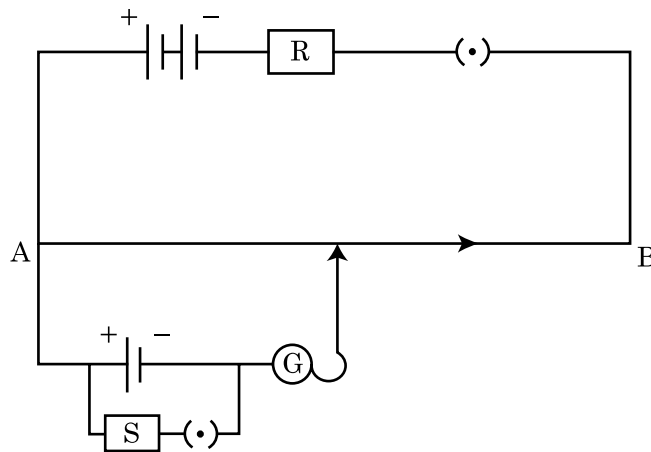

Keeping other things unchanged (a) X increases the value of resistance R, (b) Y decrease the value of resistance S in the set up. How will these changes affect the position of null point in each case and why?

OR

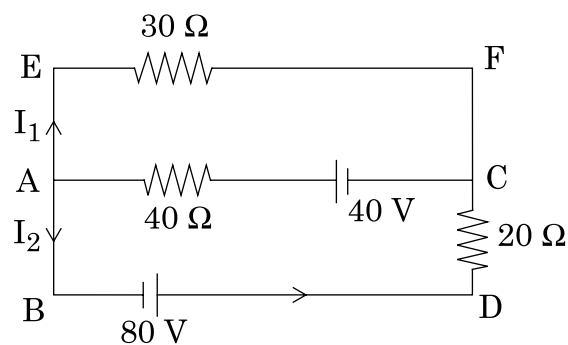

- (a) Use Kirchhoff's rules, calculate the current in the arm AC of the given circuit.
 (b) On what principle does the meter bridge work? Why are the metal strips used in the bridge?

MARKING SCHEME

SET 55/1/S

Q. No.	Expected Answer / Value Points	Marks	Total Marks						
Section A									
Set1,Q1 Set2,Q3 Set3,Q2	(i) Manganin (ii) $R = \frac{\rho l}{A}$. As ρ increases A also increases Alternatively, $R_c = \rho_c \frac{l}{A_c}; R_m = \rho_m \frac{l}{A_m}$. since $\rho_m > \rho_c \therefore A_m > A_c$	1/2 1/2	1						
Set1,Q2 Set2,Q2 Set3,Q5	Phase angle = 60° [Note : If the student only writes, $[\cos \phi = 0.5]$, give 1/2 mark]	1	1						
Set1,Q3 Set2,Q1 Set3,Q4	Between plates of capacitor during charging / discharging Alternatively, In the region of time varying electric field	1	1						
Set1,Q4 Set2,Q5 Set3,Q1	(i) P = NOT gate (ii) Q = OR gate	1/2 1/2	1						
Set1,Q5 Set2,Q4 Set3,Q3	Def: The average time, between successive collisions of electrons, (in a conductor) is known as relaxation time	1	1						
Section B									
Set1,Q6 Set2,Q6 Set3,Q10	<table border="1" style="width: 100%; border-collapse: collapse;"> <tr> <td style="width: 70%;">Electrostatic Shielding</td> <td style="width: 30%; text-align: center;">1/2</td> </tr> <tr> <td>Using this property in actual practice</td> <td style="text-align: center;">1</td> </tr> <tr> <td>Potential in a cavity</td> <td style="text-align: center;">1/2</td> </tr> </table> <p>The field inside a conductor is zero.</p> <p>Sensitive instruments are shielded from outside electrical influences by enclosing them in a hollow conductor . (any other relevant answer.)</p> <p>Potential inside the cavity is not zero/ potential is constant.</p>	Electrostatic Shielding	1/2	Using this property in actual practice	1	Potential in a cavity	1/2	1/2 1 1/2	2
Electrostatic Shielding	1/2								
Using this property in actual practice	1								
Potential in a cavity	1/2								
Set1,Q7 Set2,Q7 Set3,Q8	<table border="1" style="width: 100%; border-collapse: collapse;"> <tr> <td style="width: 70%;">Two properties of electromagnetic waves</td> <td style="width: 30%; text-align: center;">1/2 + 1/2</td> </tr> <tr> <td>Showing e m waves have momentum</td> <td style="text-align: center;">1</td> </tr> </table> <p>Any two properties of electromagnetic waves Such as (a) transverse nature (b) does not get deflected by electric fields or magnetic fields (c) same speed in vacuum for all waves (d) no material medium required for propagation (e) they get refracted, diffracted and polarised / (any two properties)</p> <p>Electric charges present on a plane, kept normal to the direction of propagation of an e.m. wave can be set and sustained in motion by the electric and magnetic field of the electromagnetic wave. The charges thus acquire energy and momentum from the waves.</p>	Two properties of electromagnetic waves	1/2 + 1/2	Showing e m waves have momentum	1	1/2 + 1/2 1	2		
Two properties of electromagnetic waves	1/2 + 1/2								
Showing e m waves have momentum	1								

	<p>Alternatively Radiation Pressure – Electromagnetic waves exert radiation pressure. Hence, they carry momentum.</p>		2								
Set1,Q8 Set2,Q8 Set3,Q9	<table border="1"> <tr> <td>Principle</td> <td>½</td> </tr> <tr> <td>Calculation of λ</td> <td>1 ½</td> </tr> </table> <p>Diffraction effects are observed for beams of electrons scattered by the crystals</p> $\lambda = \frac{1.227nm}{\sqrt{V}}$ $\lambda = \frac{1.227nm}{\sqrt{120}}$ <p>Value $\lambda = 0.112nm$</p> <p>Alternatively</p> $\lambda = \frac{h}{\sqrt{2meV}}$ $= \frac{6.63 \times 10^{-34}}{\sqrt{2 \times 9.1 \times 10^{-31} \times 1.6 \times 10^{-19} \times 120}}$ $\lambda = 0.112nm$	Principle	½	Calculation of λ	1 ½	½ ½ ½ ½ ½ ½ ½	2				
Principle	½										
Calculation of λ	1 ½										
Set1,Q9 Set2,Q10 Set3,Q7	<table border="1"> <tr> <td>Function of Transducer</td> <td>1</td> </tr> <tr> <td>Function of Repeater</td> <td>1</td> </tr> </table> <p>(i) Transducer: The device which converts one form of energy into another</p> <p>(ii) Repeater: A repeater picks up signal, amplifies and retransmits them to receiver</p>	Function of Transducer	1	Function of Repeater	1	1 1	2				
Function of Transducer	1										
Function of Repeater	1										
Set1,Q10 Set2,Q9 Set3,Q6	<table border="1"> <tr> <td>Finding the principal quantum number</td> <td>1</td> </tr> <tr> <td>Finding the total energy</td> <td>1</td> </tr> </table> <p>(i) $r = r_0 n^2$ $21.2 \times 10^{-11} = 5.3 \times 10^{-11} n^2$ implies $n = 2$</p> <p>(ii) $E = \frac{-13.6eV}{n^2}$ $= \frac{-13.6eV}{2^2} = -3.4eV$</p> <p>[Award ½ mark if the student just writes $E = E_1/4$]</p> <p style="text-align: center;">OR</p> <table border="1"> <tr> <td>Calculation of energy of photon</td> <td>1½</td> </tr> <tr> <td>Identification of transition</td> <td>½</td> </tr> </table> <p>(i) Energy of photon $= \frac{hc}{\lambda} = \frac{6.64 \times 10^{-34} \times 3 \times 10^8}{275 \times 10^{-9} \times 1.6 \times 10^{-18}} eV = 4.5 eV$</p> <p>(ii) The corresponding transition is B</p>	Finding the principal quantum number	1	Finding the total energy	1	Calculation of energy of photon	1½	Identification of transition	½	½ ½ ½ ½ ½ + ½ ½	2
Finding the principal quantum number	1										
Finding the total energy	1										
Calculation of energy of photon	1½										
Identification of transition	½										

Section C

Set1,Q11
Set2,Q20
Set3,Q22

Diagram	1
Deriving expression for E_{eq}	1 ½
Direction of E_{eq}	½

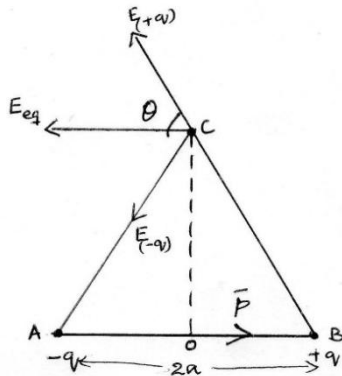

$E_{+q} = Kq / (r^2 + a^2)$ and $E_{-q} = Kq / (r^2 + a^2)$

The two Electric fields have equal magnitudes and their directions are as shown in diagram

Components along dipole axis get added up while normal components cancel each other.

$$\therefore \mathbf{E} = -[E_{-q} + E_{+q}] \cos\theta \hat{r} \text{ so } E = -\frac{K2qa}{[r^2 + a^2]^{\frac{3}{2}}} \hat{r}$$

$$= \frac{kp}{[r^2 + a^2]^{\frac{3}{2}}} \text{ (} p = 2qa\hat{r} \text{)} = \frac{-1}{4\pi\epsilon_0} \frac{p}{[r^2 + a^2]^{\frac{3}{2}}}$$

\therefore Direction of electric field is opposite to that of dipole moment.

Set1,Q12
Set2,Q15
Set3,Q16

a) To find charge accumulated in capacitor C_2	½
b) To find the ratio of energy stored	2 ½

a) Zero

b) We have $C_{series} = \frac{3\mu F}{3} = 1 \mu F$

Also, $C_{parallel} = (3+3+3) = 9\mu F$

Energy stored = $\frac{1}{2} CV^2$

\therefore Energy in series combination = $\frac{1}{2} 1 \times 10^{-6} \times V^2$

Energy in parallel combination = $\frac{1}{2} 9 \times 10^{-6} \times V^2$

\therefore Ratio = 1:9

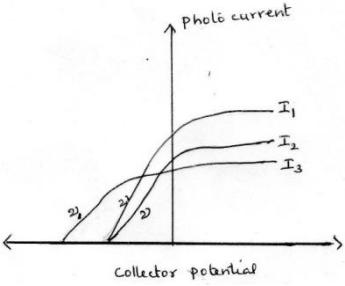

Set1,Q13 Set2,Q16 Set3,Q19	<p>a) Definition of intensity 1 b) Required graph 1 c) Explanation of nature of the curves 1</p> <p>a) Intensity of radiation equals the energy of all the Photons incident normally per unit area per unit time. Alternatively, The intensity of radiation is proportional to the number of photons emitted per unit area per unit time. 1</p> <p>b)  1</p> <p>c) As per Einstein's equation, (i) The stopping potential is same for I₁ and I₂ as they have the same frequency. 1/2 (ii) The saturation currents are as shown , because I₁ > I₂ > I₃ 1/2 3</p>		
Set1,Q14 Set2,Q14 Set3,Q12	<p>(i) To explain the process of emission 1 (ii) Material preferred to make LED and reason 1/2 + 1/2 (iii) Two advantages of using LED 1/2 + 1/2</p> <p>(i) During Forward bias of LED, electrons move from n side to p side and holes move from p side to n side. During recombination, energy is released in the form of photons having energy $h\nu$ of the order of band gap. 1</p> <p>(ii) GaAs/ GaAsP (any one) 1/2</p> <p>Band gap should be 1.8 eV to 3 eV These materials have band gap which is suitable to produce desired visible light wavelengths. 1/2</p> <p>(iii) Low operational voltage, fast action , no warm up time required, nearly monochromatic, long life , ruggedness, fast on and off switching capacity. 1/2 + 1/2 3 (any two points)</p>		
Set1,Q15 Set2,Q13 Set3,Q14	<p>Calculation of capacitance 1 Calculation of Impedence 1 Calculation of Power dissipated 1</p> <p>Capacitance = $C = \frac{1}{L\omega^2}$ $= \frac{1}{\frac{4}{\pi^2}(2\pi \times 50)^2} \text{F}$</p>	1/2 1/2	

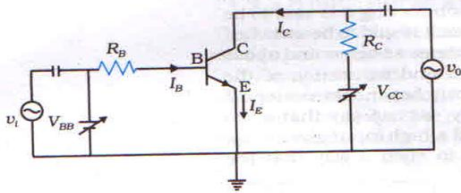
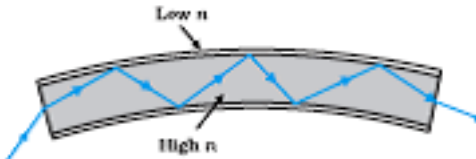

	$= 2.5 \times 10^{-5} F$ <p>Impedence = resistance(since V and I are in phase) \therefore Impedence = 100Ω Power discipated = $\frac{E_{rms}^2}{R}$ $= \frac{(200)^2}{100} W = 400 \text{ watt}$</p>	$\frac{1}{2}$ $\frac{1}{2}$ $\frac{1}{2}$ $\frac{1}{2}$	3
Set1,Q16 Set2,Q19 Set3,Q20	<div style="border: 1px solid black; padding: 5px; margin-bottom: 10px;"> <p>(i) To calculate angle of prism 1 ½</p> <p>(ii) To trace the path of incident light inside the prism 1 ½</p> </div> <p>(i) $\mu = \frac{\sin\left(\frac{A+D}{2}\right)}{\sin\frac{A}{2}}$ $= \frac{\sin\left(\frac{2A}{2}\right)}{\sin\frac{A}{2}} = 2\cos\frac{A}{2} = \sqrt{3}$ $\therefore A = 60^\circ$</p> <p>(ii) $\mu = \sqrt{3} = \frac{1}{\text{sini}_c}$ $\therefore \text{sini}_c = \frac{1}{\sqrt{3}} \cong 0.58$ Lies between 30° and 45° Hence, TIR takes place. Alternatively, $\text{sinc} = \frac{1}{\sqrt{3}}$ which is less than $\frac{1}{\sqrt{2}}$ \therefore angle of incidence $> i_c$ \therefore TIR</p>	$\frac{1}{2}$ $\frac{1}{2}$ $\frac{1}{2}$ $\frac{1}{2}$	1
Set1,Q17 Set2,Q18 Set3,Q17	<div style="border: 1px solid black; padding: 5px; margin-bottom: 10px;"> <p>To plot (BE/A) vs mass number graph 1½</p> <p>To state the property of nuclear force ½</p> <p>To explain the release of energy in fission and fusion using the graph ½ + ½</p> </div> <p>Nuclear force is Saturated, or short ranged [any one]</p> <p>The final system is more tightly bound when heavy nucleus undergoes nuclear fission. Hence, there is a release of energy.</p> <p>The final system is more tightly bound when light nuclei undergoes nuclear fusion. Hence, there is a releases of energy.</p>	$\frac{1}{2}$ $\frac{1}{2}$ $\frac{1}{2}$	3

	<p>Alternatively : There is an increase in BE/nucleon both during</p> <p>(i) Nuclear fission of heavy nuclei and</p> <p>(ii) Nuclear fusion of light nuclei</p>	1/2 1/2	3
Set1,Q18 Set2,Q17 Set3,Q18	<div style="border: 1px solid black; padding: 5px; margin-bottom: 10px;"> <p>To draw circuit diagram of amplifier 1 1/2</p> <p>Deriving the expression for β_{ac} 1 1/2</p> </div> <p>a) </p> <p>b)</p> $A_V = \beta_{ac} \cdot \frac{R_L}{r}$ $\therefore \beta_{ac} = A_V \frac{r}{R_L}$ <p>Alternatively: [If the student writes $\beta_{ac} = \frac{\delta I_C}{\Delta I_B}$ award full credit]</p>	2 1	3
Set1,Q19 Set2,Q22 Set3,Q21	<div style="border: 1px solid black; padding: 5px; margin-bottom: 10px;"> <p>(i) Naming the phenomenon 1</p> <p>(ii) Two conditions for TIR 1/2 + 1/2</p> <p>(iii) Labelled diagram of optical fibre 1</p> </div> <p>(i) Total internal reflection</p> <p>(ii) Rays of light have to travel from optically denser medium to optically rarer medium and Angle of incidence in the denser medium should be greater than critical angle</p> <p>(iii)</p> <div style="text-align: center;">  </div> <p>[Note: Deduct 1/2 mark if labelling is not done]</p>	1 1/2 1/2 1	3
Set1,Q20 Set2,Q12 Set3,Q15	<div style="border: 1px solid black; padding: 5px; margin-bottom: 10px;"> <p>Three applications of internet 1/2 + 1/2 + 1/2</p> <p>Explanation of any one 1 1/2</p> </div> <p>Applications of internet- e mail, social networking sites, e –commerce, mobile telephony, GPS, [Any three]</p> <p>Explanation of any one</p>	1/2 + 1/2 + 1/2 1 1/2	3

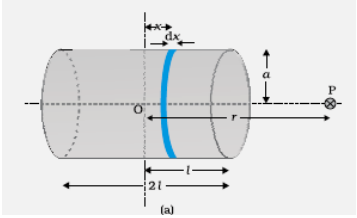

Set1,Q21 Set2,Q11 Set3,Q11	<div style="border: 1px solid black; padding: 5px; margin-bottom: 10px;"> <p>To show that the intensity of maximum is four times the intensity of light from each slit 2</p> <p>Conditions for constructive and destructive interference $\frac{1}{2} + \frac{1}{2}$</p> </div> <p>Resultant displacement</p> $y = y_1 + y_2$ $= a[\cos(\omega t) + \cos(\omega t + \phi)]$ $= 2a \cos\left(\frac{\phi}{2}\right) \cos\left(\omega t + \frac{\phi}{2}\right)$ <p>\therefore amplitude of resultant wave $= 2a \cos\left(\frac{\phi}{2}\right)$</p> <p>$\therefore$ Intensity $= 4I_o \cos^2\left(\frac{\phi}{2}\right)$, where $I_o = a^2$ is the intensity of each harmonic wave</p> <p>At the maxima, $\phi = \pm 2n\pi \therefore \cos^2\frac{\phi}{2} = 1$</p> <p>At the maxima, $I = 4I_o = 4 \times$ intensity due to one slit</p> $I = 4I_o \cos^2\left(\frac{\phi}{2}\right)$ <p>For constructive interference, I is maximum</p> <p>It is possible when $\cos^2\left(\frac{\phi}{2}\right) = 1; \frac{\phi}{2} = n\pi; \phi = 2n\pi$</p> <p>For destructive interference, I is minimum, i.e., $I=0$</p> <p>It is possible when $\cos^2\left(\frac{\phi}{2}\right) = 0; \frac{\phi}{2} = \frac{(2n-1)\pi}{2}; \phi = (2n \pm 1) \frac{\pi}{2}$</p>	<p>$\frac{1}{2}$</p> <p>$\frac{1}{2}$</p> <p>$\frac{1}{2}$</p> <p>$\frac{1}{2}$</p> <p>$\frac{1}{2}$</p> <p>$\frac{1}{2}$</p> <p>$\frac{1}{2}$</p>	<p>3</p>
Set1,Q22 Set2,Q21 Set3,Q13	<div style="border: 1px solid black; padding: 5px; margin-bottom: 10px;"> <p>(i) Two properties of soft iron $\frac{1}{2} + \frac{1}{2}$</p> <p>(ii) Statement of Gauss's law in magnetism 1</p> <p>Difference and Explanation $\frac{1}{2} + \frac{1}{2}$</p> </div> <p>(i) Low coercivity and high permeability $\frac{1}{2} + \frac{1}{2}$</p> <p>(ii) The net magnetic flux through any closed surface is zero/ $\oint B \cdot ds = 0$ $\oint E \cdot ds = \frac{q}{\epsilon_0}$ / The net electric flux through any closed surface is $\frac{1}{\epsilon_0}$ times the net charge. $\frac{1}{2}$ $\frac{1}{2}$ which indicates magnetic monopoles do not exist/ magnetic poles always exists in pairs</p> <p>[Note : If the student just states Gauss's Law in electrostatics these 2 marks may be awarded.]</p> <p style="text-align: center;">OR</p> <div style="border: 1px solid black; padding: 5px; margin-top: 10px;"> <p>a) Deriving the expression for Magnetic field at a point outside the current carrying solenoid 2</p> <p>b) Writing the condition 1</p> </div>	<p>$\frac{1}{2} + \frac{1}{2}$</p> <p>1</p> <p>$\frac{1}{2}$</p> <p>$\frac{1}{2}$</p>	<p>3</p>

	 <p>a) The magnitude of the total field is obtained due to small elements</p> $dB = \frac{\mu_0 n dx l a^2}{2[(r-x)^2 + a^2]^{\frac{3}{2}}}$ <p>x varies from $x = -l$ to $x = +l$</p> $B = \frac{\mu_0 n l a^2}{2} \int_{-l}^l \frac{dx}{[(r-x)^2 + a^2]^{\frac{3}{2}}}$ <p>For $r \gg a$ and, we have $r \gg x$</p> $B \simeq \frac{\mu_0 n l a^2}{2r^3} \int_{-l}^l dx = B = \frac{\mu_0 n l a^2 (2l)}{2r^3}$ <p>Here magnetic moment $m = n2l(\pi a^2)$</p> $\text{Thus } B = \frac{\mu_0 2m}{4\pi r^3}$ <p>This is also the far axial magnetic field of a bar magnet. Hence, the magnetic field, due to current carrying solenoid along its axial line is similar to that of a bar magnet for far off axial points.</p>	<p>1/2</p> <p>1/2</p> <p>1/2</p> <p>1/2</p> <p>1</p>	<p>3</p>						
Section D									
<p>Set1,Q23 Set2,Q23 Set3,Q23</p>	<table border="1" style="width: 100%;"> <tr> <td>a) Two values</td> <td style="text-align: right;">1+1</td> </tr> <tr> <td>b) Reason</td> <td style="text-align: right;">1</td> </tr> <tr> <td>c) Reason, for why power is transmitted at high voltage</td> <td style="text-align: right;">1</td> </tr> </table> <p>a) Caring, helpful, presence of mind (or any other (two) relevant values)</p> <p>b) Current passes between two points only when there is a potential difference between them/</p> <p>c) To minimise power loss during transmission.</p>	a) Two values	1+1	b) Reason	1	c) Reason, for why power is transmitted at high voltage	1	<p>2</p> <p>1</p> <p>1</p>	<p>4</p>
a) Two values	1+1								
b) Reason	1								
c) Reason, for why power is transmitted at high voltage	1								
Section E									
<p>Set1,Q24 Set2,Q25 Set3,Q26</p>	<table border="1" style="width: 100%;"> <tr> <td>(i) To find the magnitude and the direction of current in 1Ω resistor</td> <td style="text-align: right;">3</td> </tr> <tr> <td>(ii) (Shift and reason) in each case</td> <td style="text-align: right;">$(\frac{1}{2} + \frac{1}{2}) \times 2$</td> </tr> </table>	(i) To find the magnitude and the direction of current in 1Ω resistor	3	(ii) (Shift and reason) in each case	$(\frac{1}{2} + \frac{1}{2}) \times 2$				
(i) To find the magnitude and the direction of current in 1Ω resistor	3								
(ii) (Shift and reason) in each case	$(\frac{1}{2} + \frac{1}{2}) \times 2$								

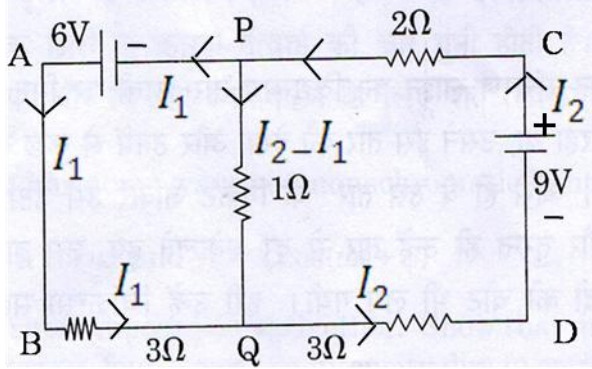

For the mesh APQBA

$$-6 - 1(I_2 - I_1) + 3I_1 = 0$$

$$\text{Or } -I_2 + 4I_1 = 6 \dots\dots\dots(1)$$

For the mesh PCDQP

$$2I_2 - 9 + 3I_2 + 1(I_2 - I_1) = 0$$

$$\text{Or } 6I_2 - I_1 = 9 \dots\dots\dots(2)$$

Solving (1) and (2), we get

$$I_1 = \frac{45}{23} \text{ A}$$

$$I_2 = \frac{42}{23} \text{ A}$$

$$\therefore \text{Current through the } 1\Omega \text{ resistor} = \frac{-3}{23} \text{ A}$$

a) Balancing length increases

When series resistance increases, the potential gradient decreases. Hence l increases. Null point shifts towards point B.

b) Balancing length decreases

$V = E - I'r$. As I' increases V decreases. Hence balancing length decreases. Null point shifts towards A.

OR

a) To calculate the current in the arm AC	3
b) Principle of meter bridge	1
c) Why metal strips are used in meter bridge	1

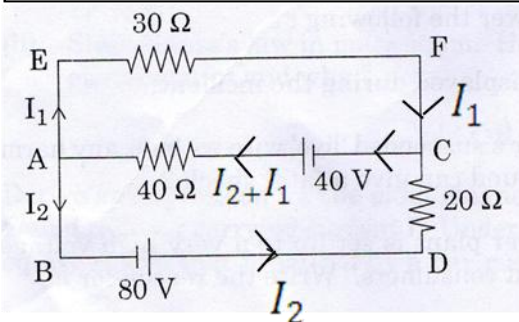

For the mesh EFCAE

$$-30I_1 + 40 - 40(I_1 + I_2) = 0$$

$$\text{Or } -7I_1 - 4I_2 = -4$$

$$\text{Or } 7I_1 + 4I_2 = 4 \dots\dots\dots(1)$$

1

1

1/2

1/2

1/2

1/2

1/2

1/2

5

1

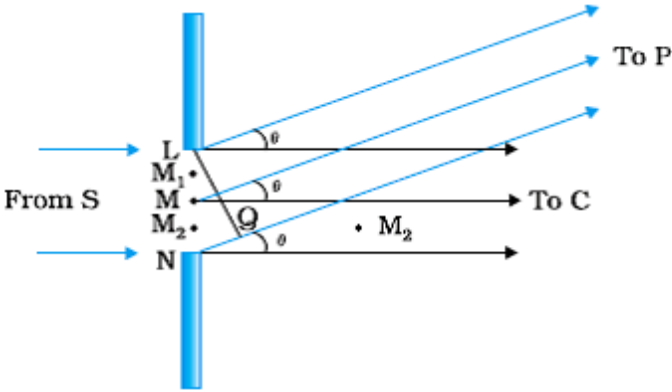
	<p>(i) Magnetic field at the centre of the coil $B_1 = \frac{\mu_0 NI}{2R}$</p> <p>Magnetic field at the outside point $B_2 = \frac{\mu_0 N I R^2}{2[R^2 + 3R^2]^{\frac{3}{2}}} = \frac{\mu_0 N I R^2}{2[4R^2]^{\frac{3}{2}}} = \frac{\mu_0 NI}{2 \cdot 8R}$</p> <p>$\frac{B_1}{B_2} = 8$</p> <p>[Note :If the student takes $r = \sqrt{3} R$, the ratio of B centre to B axial would be $3\sqrt{3} : 1$. Award 1 mark in this case also.]</p> <p style="text-align: center;">OR</p> <table border="1" style="width: 100%; border-collapse: collapse;"> <tr> <td>a) Velocity selection condition</td> <td style="text-align: right;">1</td> </tr> <tr> <td>b) Name of device</td> <td style="text-align: right;">$\frac{1}{2}$</td> </tr> <tr> <td>What does the machine do</td> <td style="text-align: right;">$\frac{1}{2}$</td> </tr> <tr> <td>Use of two fields</td> <td style="text-align: right;">$\frac{1}{2} + \frac{1}{2}$</td> </tr> <tr> <td>Regions of existence of field</td> <td style="text-align: right;">$\frac{1}{2} + \frac{1}{2}$</td> </tr> <tr> <td>Nature of fields</td> <td style="text-align: right;">$\frac{1}{2} + \frac{1}{2}$</td> </tr> </table> <p>a) $qE = Bqv$ $v = E/B$</p> <p>b) Name of the device: Cyclotron It accelerates charged particles/ions Electric field accelerates the charged particles. Magnetic field makes particles to move in circle. Electric field exists between the Dees. Magnetic field exists both inside and outside the dees. Magnetic field is uniform / constant. Electric field is oscillating/ alternating in nature.</p>	a) Velocity selection condition	1	b) Name of device	$\frac{1}{2}$	What does the machine do	$\frac{1}{2}$	Use of two fields	$\frac{1}{2} + \frac{1}{2}$	Regions of existence of field	$\frac{1}{2} + \frac{1}{2}$	Nature of fields	$\frac{1}{2} + \frac{1}{2}$	<p>$\frac{1}{2}$</p> <p>$\frac{1}{2}$</p> <p>2</p> <p>1</p> <p>$\frac{1}{2}$</p> <p>$\frac{1}{2}$</p> <p>1</p> <p>1</p> <p>1</p> <p>1</p>	<p>5</p> <p>5</p>
a) Velocity selection condition	1														
b) Name of device	$\frac{1}{2}$														
What does the machine do	$\frac{1}{2}$														
Use of two fields	$\frac{1}{2} + \frac{1}{2}$														
Regions of existence of field	$\frac{1}{2} + \frac{1}{2}$														
Nature of fields	$\frac{1}{2} + \frac{1}{2}$														
<p>Set1,Q26 Set2,Q24 Set3,Q25</p>	<table border="1" style="width: 100%; border-collapse: collapse;"> <tr> <td>Explaining the formation of the diffraction pattern</td> <td style="text-align: right;">3</td> </tr> <tr> <td>Secondary maxima</td> <td style="text-align: right;">$\frac{1}{2}$</td> </tr> <tr> <td>Minima</td> <td style="text-align: right;">$\frac{1}{2}$</td> </tr> <tr> <td>Why do secondary maxima get weaker in intensity</td> <td style="text-align: right;">1</td> </tr> </table> <div style="text-align: center;">  </div>	Explaining the formation of the diffraction pattern	3	Secondary maxima	$\frac{1}{2}$	Minima	$\frac{1}{2}$	Why do secondary maxima get weaker in intensity	1	$\frac{1}{2}$					
Explaining the formation of the diffraction pattern	3														
Secondary maxima	$\frac{1}{2}$														
Minima	$\frac{1}{2}$														
Why do secondary maxima get weaker in intensity	1														

The diffraction pattern formed can be understood by adding the contributions from the different wavelets of the incident wavefront, with their proper phase differences.

For the central point, we imagine the slit to be divided into two equal halves. The contribution of corresponding wavelets, in the two halves, are in phase with each other. Hence we get a maxima at the central point. The entire incident wavefront contributes to this maxima.

All other points, for which $\theta = (n + \frac{1}{2}) \frac{\lambda}{a}$, get a net non zero contribution from all the wavelets. Hence all such points are also points of maxima.

Points for which $\theta = \frac{n\lambda}{a}$, the net contribution, from all the wavelets, is zero. Hence these points are point of minima.

We thus get a diffraction pattern on the screen, made up of points of maxima and minima.

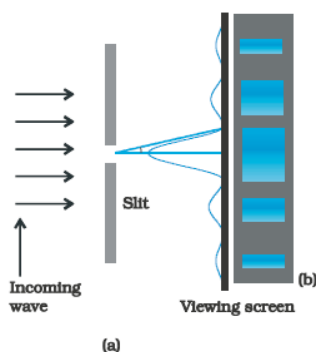

Secondary maxima keep on getting weaker in intensity, with increasing n. This is because, at the

- (i) First secondary maxima, the net contribution is only from (effectively) 1/3 rd of the incident wavefront on the slit.
- (ii) Second secondary maxima, the net contribution is only from (effectively) 1/5th of the incident wavefront on the slit. And so on.

OR

(i) Ray diagram	1
Deriving the relation between refractive indices, u and v	2
(ii) Change in focal length changes when the wavelength of light increases	1
(iii) Change in focal length changes when the lens is dipped in water	1

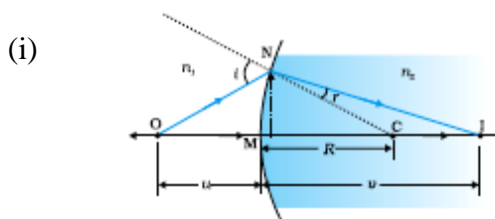

	$\tan \alpha = \frac{AN}{ON} \approx \alpha$ $\tan \beta = \frac{AN}{ON} \approx \beta$ $\tan \gamma = \frac{AN}{ON} \approx \gamma$ $\alpha + \gamma = i; r = \gamma - \beta$ $\frac{AN}{ON} + \frac{AN}{CN} = i; r = \frac{AN}{CN} - \frac{AN}{NI}$ $n_{21} = \frac{\sin i}{\sin r} \approx \frac{i}{r}$ $\frac{n_2}{n_1} = \frac{\frac{AN}{ON} + \frac{AN}{CN}}{\frac{AN}{CN} - \frac{AN}{NI}}$		
	$n_2 \left(\frac{AN}{CN} - \frac{AN}{NI} \right) = n_1 \left(\frac{AN}{ON} + \frac{AN}{CN} \right)$ $CN = R; NI = V; ON = -u$ $\frac{n_2}{v} - \frac{n_1}{u} = \frac{n_2 - n_1}{R}$		
	(ii) focal length increases with increase of wavelength		
	$\frac{1}{f} = \left(\frac{\mu_2}{\mu_1} - 1 \right) \frac{2}{R}$ <p>as wavelength increases μ_2/μ_1 decreases hence focal length increases</p>		
	(iii) As μ_1 increases focal length increases		
	$\frac{1}{f} = \left(\frac{\mu_2}{\mu_1} - 1 \right) \frac{2}{R}$		

